

# ATCO NEWSLETTER

VOLUME 15 NUMBER 3

JULY 1998

*The ATCO*

*newsletter is the official publication of a group of amateur television operators known as*  
*AMATEUR TELEVISION IN CENTRAL OHIO Group Inc."* and is published quarterly (January, April, July, and October)

Re-publication of ATCO newsletter material is encouraged as long as source credit is properly given except for  
"Reprinted by permission" material which must have original publisher's additional permission.

## ATCO WA8RUT REPEATER UPDATE

Well, let's see...things have been happening! We've got a 2.4GHz output up and running. Also, the antennas have been moved around a bit. We've fixed a filter problem and updated the controller logic. The hi/lo power problem is fixed. Want to get the full details? Read on!!!

**ATCO**

## HAM IN THE SPOTLIGHT

We welcome Dave Kibler KB8ZLB our "picture of the quarter" spotlight. For the distance (about 60 miles) Dave puts in one of the best consistent signals to the repeater. I often wondered why and was answered when I had a chance to view his antenna system in person (photo at left)! No wonder, he lives out in the country with a 65 foot tower away from trees and on high ground. (Oh, by the way, a second tower resides close by with a 20 foot long 6 meter beam at the top.) His antenna system consists of a quad array of KLM long yagi's. Gain 23dB? Dave has been at this hobby for less than 4 years so watch out guys during band openings. You're going to hear and see him often!



---

## ACTIVITIES ... from my "workbench"

Well, it's again time to summarize my (our) repeater activities. A lot has been going on, I just can't recall what it is. I'll just ramble here for a while till I remember. (Hope I don't run out of space before then)...OK, now it's getting better. Ready? Here we go!

The big ticket item this time is the relocation and addition some new repeater antennas. First the relocation effort. As you know, the 1280 MHz receive antenna was horizontally polarized. We changed it to a 12dB gain vertically polarized Comet antenna. (Now both transmit **and** receive antennas are vertically polarized.) We intend to leave it this way unless there is a logical reason to digress. Comments are invited. During the relocation effort, the removal of the horizontally polarized slot antenna resulted in a small water bath from stored water in the antenna. It was mounted upside down because of space limitations and had a leak somewhere. As a result, I am certain that the new antenna will outperform the old one! So far, that appears to be true. **BUT, now** new problems surfaced. We found that the cross polarization effects of the vertical transmit antenna and the horizontal receive antenna worked in our favor to prevent transmitter to receiver desense. With that gone, desense showed up and as yet, it's not totally cleared up. The solution is to retune the filters to optimize the separation. Until then, the system is useable.

The next thing to tackle was the 2.4 GHz transmit antenna. Up till now, the antenna was temporarily mounted to a mounting support on the roof fed with 9913. We ran 7/8" Helix and permanently mounted the antenna in the open. The 2.4 GHz receive antenna was then mounted upside down (here we go again) directly under the transmit antenna. I guess we're asking for water problems but there was nowhere else to mount it and still maintain antenna separation. We sealed the connector with that black gooey tar-like substance (I don't know what it's actually called) in the hopes that it'll be okay. We'll have to monitor the sensitivity from time to time. The only problem here is that it isn't very sensitive to start with. We have to either: 1.) get everyone to increase their transmit power, or 2.) get a better receiver. Since all of us have Wavecom's modified to output about 100 milliwatts, this seems like the best choice right now. Since the MMDS commercial TV is located on the next building, we suspect desense from them so a pair of filters are on order. We hope that's what it takes to fix it.

Dale (WB8CJW), bless his heart, spent about a 1/2 day up there troubleshooting minor problems and re-arranging things. His effort was rewarded for we now have a repeater that is able to stay in either high or low power mode, as selected, without randomly changing on us. The problem was rather embarrassing because a number of people asked me to tell them just how long after enabling high power would it automatically switch back to low power mode. They thought it was a power conservation design **feature** (I like to use the word "feature" when design bugs are the root cause). It was hard to tell them that it was a random phenomenon. The problem turned out to be an un-suppressed transmitter enable relay. Sometimes the inductive spike when the transmitter shut down toggled the controller output to low power mode so the next time...well you now know "the rest of the story". A diode across the coil solved it.

Experiments have shown that the 1 watt link transmitter (446.350 MHz) is significantly interfering with the 439.25 video input. I know that our 439 filters attenuate the 446 MHz signal by at least 40dB and the antennas are cross polarized (added 25 dB attenuation), so it shouldn't be a problem but the 446 transmitter has a 12 MHz crystal. Now, if we subtract 12 MHz from 446 MHz, we find that if any fundamental crystal energy rides through on the 446 MHz output, it'll show up at 434 MHz which is right in the 439 input passband (434 to 439 MHz lower sideband). This **COULD** be a problem. I haven't proven it yet, but if true, a bandpass filter in the 446 transmitter output will solve it. I'm looking for a good sharp bandpass filter design for 446 MHz. Anybody know of one without too much loss through it? If so, let me know so I don't go off in left field again designing things from scratch.

Back on *my* side, I also have been working on various 2.4 GHz antenna designs which are covered in more detail later in this issue. Along with that, the Wavecom modifications were performed on my units. Tom Taft (KA8ZNY), who owns a calibrated Boonton millivoltmeter good up to 10 GHz, measured the Wavecom modified transmitter output and found the signal is somewhat less than 100 mw. The paper specs suggest that greater than 200 mw should be obtainable so maybe input and (or) output matching is in order. It's difficult to obtain reliable measurements at this frequency so further experiments are in order. I've also investigated the availability of "brick" type amplifiers for this frequency and found a few. Phoenix Microwave makes an ultra linear brick amplifier that will take 35 mw input and produce 2 watts. Price...about \$190.00. Too much but my contact says they make a unit suitable for FM video modulation for somewhat over \$100.00. He is sending me specs and a quote. More news later.

I hate to even mention the rooftop camera project right now because I've been boring you with its progress for almost a year. However, it's getting close. We ran the cable to control it the last time we were at the repeater site so that's in place. The camera itself is now operational with the camera body adjusted to the lens optics. It's difficult matching it to the optical center of the lens for, if not perfect, the focus changes dramatically as the zoom goes through it's range. Work now centers more on the control electronics but that's easier since I've made similar controls before. No research here, just parts, wire and solder. Enough said...more details later.

Well, that's about all for now. There'll be more to report next time, I'm sure, so stay tuned.

...Art WA8RMC

---

## **TECH TALK...Let's learn something technical**

Ferrell Winder(W8ZCF) had a very good question about television resolution. I think that Henry (KB9FO) answered it in a way that makes it interesting and informative for all of us. Therefore it is a perfect fit into our "Tech Talk" section this time. Thanks for the info, Henry.

### **Dear Henry,**

Some time ago you gave me a very good discussion on resolution. I'm doing some further amateur ATV experiments now and would again like to have your additional comments. My set up is a PC70-10, a RFC 4-110 and an FO-22. A station over 50 miles distant sees about 240 lines from me. I'm trying to determine what might be the limiting factors. I'm pointed at a wedge test pattern with a Sony camera. The TP goes down to 325 lines. With the camera feeding the video input of a Sony monitor I see somewhat in excess of 250 lines. This setup is of course limiting the possible horizontal resolution. I know that the resolution capability is about 80 lines/MHz BW. In talking with a couple of the Chief Engrs of local commercial TV stations they lead me to believe they are broadcasting resolution in excess of 320 lines, one claims a little over 400 lines and he says also that a good TV recvr (home type) should be able to receive 400 lines! This surprises me but I have no way to easily check this out. The commercial stations around here never run a resolution pattern anymore. I understand you are in the commercial TV business and can probably set me straight on what you are broadcasting out of the antenna and what the best I might see from a commercial station on my Sony type set. I have a feeling my Sony is probably not passing more than about 250 lines thru just the video circuit. Then when an off air signal is rec'd the IF and the post detection low pass filters probably hold it to around 240 lines?

Your comments would be very much appreciated. Have you had experience with ATV setups with resolutions considerably beyond 240 lines? Thanks for any comments, 73, Farrell, W8ZCF.

### **Henry replies,**

Ah the resolution maze! (See ATVQ a few years ago). First, the resolution at a distance is inversely proportional to the distance in that the sidebands which carry high frequency information disappear into the noise before the lower sidebands which carry lower frequency information. If you look on a spectrum analyzer, the pyramid shape of the sidebands shows how fast they go away. If you hold a horizontal line across the display, you will note that the -20 dB sidebands are about 20-30 dB above the noise floor of 50-60 dB. So as the signal gets weaker, the "bandwidth" gets narrower. A clever design of NTSC in that it reduces the detail with an increase in noise but the picture is still discernable even in heavy noise (snow).

Many TV sets still use a bandpass filter to separate chroma and luma signals. The TV set therefore hardly makes 240 lines (3 MHz) of resolution. The direct video input is limited to the pitch and video resolution. A fine pitch monitor has more detail than a low pitch (same as computer VGA res). A B&W monitor can easily display 600-800 or more lines of resolution (80 lines = 1 MHz) since it is not bandwidth limited but is limited by the spot of the beam diameter. (aperture)

Then there are a host of optical reasons... we need a book to discuss that. Lastly, resolution in a monitor or camera is measured at the center of the display, and is a function of height in most specs. So 400 lines is not 400 lines that you can count, it is a function of resolution and likely the kell effect and aperture effect limit it to about 2/3 of what they state. In tubes (image and picture) there is also a depth of modulation curve, which says you may be able to see 400 lines, but about 150 at full b/w ratio. As the curve reaches the limit of resolution, the depth of modulation turns the alternating lines into gray.

I would worry less about the resolution than the S/N ratio, since the picture detail is ultimately noise limited. At 60 dB the test signal generator S/N ratio is the best you gonna see. As the signal/noise ratio goes down, so does the ability to get all the detail. A P5 signal (here comes controversy) is about 40-45 dB S/N, and about 6 dB less per P unit. You need about 20 dB S/N ratio to get a locked in barely discernable image. So work on the receiver sensitivity (system losses) and TX power. 240 lines at 50 miles is pretty good even line of sight.

...Henry KB9FO

---

## **BANDPLAN TALK AGAIN...comment period's over but here's added thoughts .**

The ARRL asked the FCC for a summary ruling on (if you read through all the double talk and decipher the two requests at the beginning and end of their request) whether a local band plan = good amateur practice. In other words, if the local FM boys devise a bandplan, and if they leave you out, if said bandplan is prima facia accepted as good amateur practice, you are forced off the air. Catching them red handed trying to make rules that do not exist, several hams were able to get the FCC to open this for comment via RM 6259.

Suggestion: Yes, the national band plans published by the ARRL are technically flawed, but it has allowed all permitted modes to exist on the bands permitted. The local band plans in most part also work. However, the ARRL's efforts to organize the VHF/UHF frequencies via NFCC/SPOC, has generated a lot of concern on the part of non FM mode users. The concern is that the NFCC, which has already publically stated their rejection, abhorrence and desire to eliminate certain legal modulation schemes from the

popular bands, would displace and harm all license holders, and ultimately harm ham radio in general by making it less attractive to those who would pioneer, experiment and otherwise develop communications systems now permitted by the FCC and now accommodated in the band plans. Only a band plan that permits all modes and users technically acceptable operation should be considered FCC legal. Those band plans which exclude modes or groups of users from enjoying their license granted privileges to use modes permitted should not be allowed any status.

Avoid picking on any particular mode, as this affects all band users, and all modulations. Give examples of good and bad local band plans that have failed to provide adequate or technically sound provisions for various modes.

Further, arguments that the bands are full, don't hold water. Crowding on the ham bands has been the impetus to move to new and usually higher bands, which spurs technical development. This was true for 2 meters, 440 and every other band where there were first a few weak signal pioneers, then a few FM'ers, then when the band was proved to be useful, the hoards of HT users piled in. Its time we began to fill 6, 220 and 1296 which is vacant in 98% of the country. And anyone with a scanner can tell you that even 2 and 440 are mostly unused much of the day with seldom more than a handful of active repeaters in use in even the most populated areas. When you get to the boonies, you're lucky to find anyone on the one local repeater outside of drive time and early evening.  
...Henry KB9FO

This new rule can work for or against ATVerS depending on how you work out the local band plan with others. It will force all mode, full band planning. If it goes through, I believe ATVerS and those of all the modes will have to come together to work out a local band plan. All legal modes must be accommodated on each band. So how involved your local ATV group gets will determine how many channels, in/out freq. of ATV repeaters, etc. you will have. In addition, the agreed to local band plan will afford some notification and legal protection from other modes interfering within the ATV passband.

...Tom O'Hara W6ORG

---

### **432 MHz...then and now**

In the beginning, there was 432.00. Everyone was there, weak signal, ATV, EME, etc. Eventually the WS guys and ATV guys got on each others nerves because the WS guys could not copy CW though the video sidebands. It was decided that 439.25 would be far enough away from the WS guys that they could both enjoy the band and never interfere with each other. WS started to spread around to 432.1 and up a little, settling on calling frequencies, beacon frequencies, and chat /DX frequencies, all within a few dozen kHz. Beams were mostly home made, K2RIW yagi's tuned for 432, and K2RIW amps tuned to 432. They worked at 439.25 too, and versions for ATV came along. Enter a little company called PC Electronics and another ATV Research. Mel Shadbolt (ATVR) started selling kits for TV cameras, you even wound your own deflection coils. W8DMR (Columbus, OH) got a nice set of articles in Radio Electronics and QST about it. Soon Wayne Green had the idea that ATV might be fun. So W2NSD had Mel start a little newsletter called ATV Experimenter and WG printed it. Wayne had other little flyer type publications while he started 73 after getting kicked out of CQ. After about 6 years, ATV E gave out. Meanwhile PCE had started by selling modulators for RCA CMU-15's and other little nifty kits and PC boards to video modulate the early FM gear that was beginning to show up in the late 60's and early 70's. Then W0LMD and W9NTP and a Cophorn McDonald got the idea for SSTV, based on CM's thesis for college. Sure enough that worked. Meanwhile a couple of NJ hams started A5 to promote SSTV. That lasted about 2 years when it moved to Philly where 2 more hams tried it as a FSTV and SSTV mag... Well somewhere along the way John Huntoon (ARRL) and Charlie Higgenbotham (FCC) decided that the early FM'ers might need a lot of guidance to keep from stepping on the other modes. ARRL had already had a meager bandplan, but formed the VUAC to make a new one. the VUAC basically took the existing WS/ATV and FM stuff and pasted it into a new band plan. Opps, they forget that ATV was 6 MHz wide, not 30 kHz, so atv at 439.25 was OK, but the FM band was stuck at 440-450. That started the FM into ATV problem. The ARRL never got any incentive to change it, and FM was gaining ground faster than Motorola could toss out radios. The US ham radio manufacturers (yes there were several back then) started to make 2 meter and even some 440 FM radios. Some were just imports with new names stuck on, some were US made. Clegg, Polycom, Standard, Icom, Drake, Swan, and others started to put stuff out anyone one could use. Before that it was RCA, GE, Link, Mother Batwing. 2 meters began filling up 146-147 and started to spill into 157-148. Fearing that FM would take over, we got a bunch of new ARRL/FCC FM repeater rules and FC's starting appearing in various areas to coordinate repeaters. Of course the band plan didn't get revisited. Keep in mind one of the band plan authors was an ATVer. Well before you knew it, lack of foresight and planning wound up as a mess on 70 cm, because FM grew so fast. But ARRL was mostly interested in HF only and gave VHF little thought. Now a few enterprising souls calling themselves MACC decided it was time to reverse the situation and kick ATV and others off the "FM" bands, first by declaring that they would no longer coordinate ATV, and then a year later saying they would only "actively discourage ATV." Lacking the oomph to do it, they got some pals at HQ to join in their effort to save the bands for FM, and began the SPOC/NFCC effort. And that's how we got to where we are today.

...Henry KB9FO

---

## 1240-1300MHz (23cm) ATV BANDPLAN THOUGHTS

I was asked by a ham, "what FM ATV frequency would you suggest using in the 23cm band". So I dug out an old paper I wrote, and except for revising my old area code, I think it is still valid today. In Southern California, ATVers opted to use the 5 channels in the 23cm band for simplex and ATV repeater outputs. We don't use FM until 2.4 GHz. (in California) but I submit my thoughts below for any help in your area 23cm band plan considerations.

### **Dec 12, 1990 ...For publication in the Repeater Coordinators Newsletter...23 cm FM ATV Coordination**

When the 23 cm ARRL band plan was formulated in the early 80's, FM ATV was being experimented with by just a handful. It was determined that even though the occupied bandwidth would exceed the 10 MHz wideband experimental slot centered at 1265 by a little for FM ATV simplex (it would stay inside if no sound subcarrier is used), there was not enough FM ATV activity at that time to warrant presenting two differing bandplans to allow for both ATV AM or FM repeaters.

In all but the most populated areas of the county, the possibility of interference from non-coordinated FM ATV on the 23 cm band will not occur for many years. But now is the time to consider and discuss local standards to minimize future hassles. If we use the modulation standards listed in Table 1, page 20-12 in the 1990 ARRL Handbook, the occupied bandwidth will be a little over 17 MHz given 4 MHz video deviation and 4.5 MHz sound (20 MHz if 6 MHz sound). One FM ATV channel will replace two of the AM ATV channels. There is no room for a combined 12 MHz slot above 1270 given existing FM voice repeaters, but the two AM ATV channels below 1260 do make it possible if there are no existing links or digital systems in place, or so few that they are willing to move.

The question then becomes what are the practical frequencies to move the FM voice link and digital channels to. The links and digital systems are sometimes duplex so they need the same input/output separation minimums as a repeater does. That says there needs to be some room on each side of the FM ATV channel rather than placing the ATV at the edge of 1240 or 1260 MHz.

Present FM voice gear, which is also used for digital systems, have programmable offset capability. Many FM voice systems use back to back synthesized mobile transceivers also, so there is no practical equipment degree of difficulty for a specific offset or frequency. There is one difficulty for an FM ATV repeater input however, if the link transmitter is located at the same site it can capture the ATV receiver, and vice-versa.

I suggest centering the FM ATV carrier at 1252 MHz. The links would then occupy 1240-1242 input pairing with 1258-1260. Which one would be the link input or output at a location would depend on whether the ATV system at 1252 was an input or output. The adjacent 1240-1242 would be the same in this case as the ATV system. Digital systems at 1242-1246 would also follow this input or output logic paired with 1297-1300. By keeping all receivers at a site regardless of mode close in frequency to each other, it allows the filters in the antenna lines to have the most rejection to the transmitters.

The frequency could just as easily be 1248 with the digital segment above the ATV segment, but 1252 is just closest to the British 1255 MHz frequency that many use now. Also the link segment at 1258-1260 is unchanged. Each area will have to get together with their local Frequency Coordinator when the first 23 cm ATV repeater is about to be built to determine whether to stay with the ARRL band plan in this segment for 2 AM systems, or modify it for an FM system.

...Tom O'Hara W6ORG

---

## **LMCC DEMANDS 70CM HAM BAND FOR COMMERCIAL USE**

*I believe that most of us have heard about the requested 70cm frequency by the LMCC (Land Mobile Communications Council) and I hope that we all responded in writing to the FCC (I did) to help preserve our precious frequency. The excerpt below helps to remind us of the ongoing struggle. As of this publication, I have heard no comments from the FCC on this subject but if any of us has any up to date news, I would appreciate hearing from you so we all may become more informed. More news as it comes in... WA8RMC*

The LMCC has issued a demand to the FCC that it immediately reallocate most of the 70 centimeter Amateur band over to private mobile operations with private land mobile designated as the primary user.

Technically the document is nothing more than a formal rule making request to the FCC that has been designated RM 9267. In reality it is more a demand by the LMCC for the FCC to immediately reallocate 420 to 430 MHz and 440 to 450 MHz away from the federal government and over to the Private Mobile Radio Service on a primary basis. The Land Mobile Communications Council is also asking for news allocations at 1390 to 1400 MHz, 1427-1432 MHz, and 1670 to 1675 MHz. It is also demanding a whopping 85 MHz at 960 to 1215 MHz and it wants all of this turned over to the Private Mobile Radio Service no later than 2010.

But LMCC is not willing to wait until 2010 to take over the 70 centimeter band even though this is the second most popular of the Amateur Radio services' VHF and UHF allocations. Amateur Radio is a secondary user of 420 to 450 MHz. There are thousands of FM repeaters operating from 440 to 450 MHz and a variety of modes on the air every day in the 420 to 430 MHz segment. While the LMCC petition indicates that it is willing to permit Amateur Radio to retain some sort of secondary status, this would be only on a non-interfering basis with the new commercial interests.

Experts say that the best way to kill RM 9267 is through a massive letter writing campaign to the FCC. A campaign that outlines the specific use of the band by Amateur Radio Interests -- informational filings that detail how every hertz of 420 to 430 and 440 to 450 MHz is utilized on a day to day basis by hams.

*The following is an additional request to the FCC by the ARRL (Bulletin 40) which sent by WIAW on June 2 and supplied to us via W6ORG. If you wish to read the entire proposal, log onto the internet at the URL below.*

### **To all radio amateurs,**

The ARRL has asked the FCC to immediately dismiss efforts by the Land Mobile Communications Council to gain primary access to 420 to 430 MHz and 440 to 450 MHz as well as other UHF allocations. The LMCC recently petitioned the FCC to reallocate the two 70cm

segments from the federal government to the Private Mobile Radio Service. Amateur Radio enjoys the use of 420 to 450 MHz on a secondary basis. In comments filed on RM-9267, the League said the LMCC proposed the switch "without establishing technical compatibility between PMRS operation and incumbent radio services in any of the bands sought."

The League said that existing federal government use of the spectrum precludes PMRS operation at 420 to 450 MHz. According to the ARRL, the petition fails to demonstrate any basis to withdraw the two band segments from federal use nor any compatibility between PMRS operation and either federal government or Amateur use. In addition, the League said, the petition fails to justify displacing established amateur operations. The League pointed out that the amateur community uses the band for public service and public safety functions and that hams have "substantial personal investment" in equipment that's in regular use there. The ARRL urged the Commission to throw out this portion of the LMCC petition "without further consideration."

The League backed up its arguments by citing documents from the National Telecommunications and Information Administration (NTIA), which manages federal spectrum. "NTIA has made it quite clear that there is no possibility of additional sharing of the 420-450 MHz band, and the unique relationship between Federal radiolocation uses and the Amateur Service cannot be duplicated by PMRS users," the ARRL said.

The ARRL said that the LMCC petition was premature because it did not take adequate account of the benefits of spectrum refarming

already initiated. The League said PMRS users should adopt already available spectrum-efficient technologies to maximize their use of existing allocations before seeking additional spectrum at the expense of other users. The League also said that PMRS users should look into using the Commercial Radio Mobile Service (CMRS). A copy of the League's comments is available at <http://www.arrl.org/news/bandthreat/RM-9267/arrl-cmt.html>.

---

## HELICOPTER 2.4 GHz VIDEO...there's a lot of activity here, folks!

On Sunday (6/7/98) we picked up something neat on our ATV repeater. The Detroit Grand Prix is televised by ABC and they had a helicopter that was sending a 2.4 GHz FM ATV signal down to their base station. With the repeater 2.4 GHz dish pointed towards Detroit we saw a P5 picture from the helicopter. What a view! Go 2.4! The helicopter was about 20 miles from the repeater building. ...Chris N8UDK

On Friday 7/3/98 during the **Red-White-Boom** fireworks ceremony in Columbus, Ohio we noticed something interfering with our 2433 MHz FM video link to the police headquarters which we were supplying to the police for crowd control observation. Bob Tournoux, KF8QU, and I were also supplying video via 920 MHz to the police which was interference free. Since our site also had 2.4 GHz receive capabilities, during a spare moment, I decided to see if I could see the remote 2433 MHz link. As I tuned around, not only did I see our link P5 but also another aerial video source. It was P5 on the Wavecom channel 2 (2465 MHz) and turned out to be the police infrared video surveillance data from a local TV station helicopter desensing our adjacent channel 1 at 2433 MHz. When we patched it down to the police headquarters and they observed it, an air of amazement was established. They wanted to know how a group of Ham Radio operators were able to intercept their security video at a quality better than they were receiving from their own monitors. (We'll let them know later.)

I have since been informed that in the Columbus, Ohio area, the 2460-2465 MHz frequency, identified as channel 9, is reserved for various portable functions including police surveillance. I wonder if the Goodyear blimp uses this frequency during Ohio State football games? Get your Wavecom's working guys and join in the fun!

...Art WA8RMC

---

## 1240-1300MHz...are we doomed?

The following thanks to SpaceNews dated MONDAY APRIL 20, 1998: GPS THREAT TO 1.2 GHz BAND

The ARRL Letter, dated 1998-Apr-04 stated that the second civilian frequency for the Global Positioning System (GPS) could wind up within Amateur Radio's secondary allocation at 1.2 GHz. A decision on whether the new, second frequency will be 1205 or 1250 MHz is expected to be made in August. An allocation at 1250 MHz could mean the end of Amateur Radio in the band between 1240 and 1260 MHz. The Amateur 23-cm band runs from 1240 to 1300 MHz.

In February 1997, the Departments of Transportation (DOT) and Defense (DOD) announced an agreement assuring civilian GPS users of a second frequency, referred to as L5, and considered essential for critical civilian GPS uses. According to a DOD news release, the White House Commission on Aviation Safety and Security, chaired by Vice President Al Gore, "called for the establishment of a second civil frequency as part of a broader program to maintain US leadership in aviation and satellite technology." Further information on this subject is available at: [http://www.defenselink.mil/news/Feb1997/b022797\\_bt095-97.html](http://www.defenselink.mil/news/Feb1997/b022797_bt095-97.html) ...[Info via John Santillo]

---

## WAVECOM POWER-UP CHANNEL MODIFICATION.

The Wavecom modification below is required to force the unit to power up on channel 4 instead of channel 1. This feature is necessary if it's used to remotely monitor channel 4 at our repeater site.

The circuit below was neatly incorporated on a small piece of vector board attached to the Wavecom main board. The Wavecom receiver was removed from its plastic case and re-installed in a die-cast aluminum enclosure for rf shielding. These units are designed to power up on channel 1 and because I didn't have any documentation to try to figure out if this feature could be modified, I decided to make an "automatic button pusher". The 555 IC is being used as an oscillator to change the channel (push the button) and keeps running until the desired channel is reached, then is held reset from the LED channel indicator output. The LED's are not being used. A small receptacle contact was removed from a junk connector and attached to the lead from R3 to allow moving to a different pin to select another channel if needed.

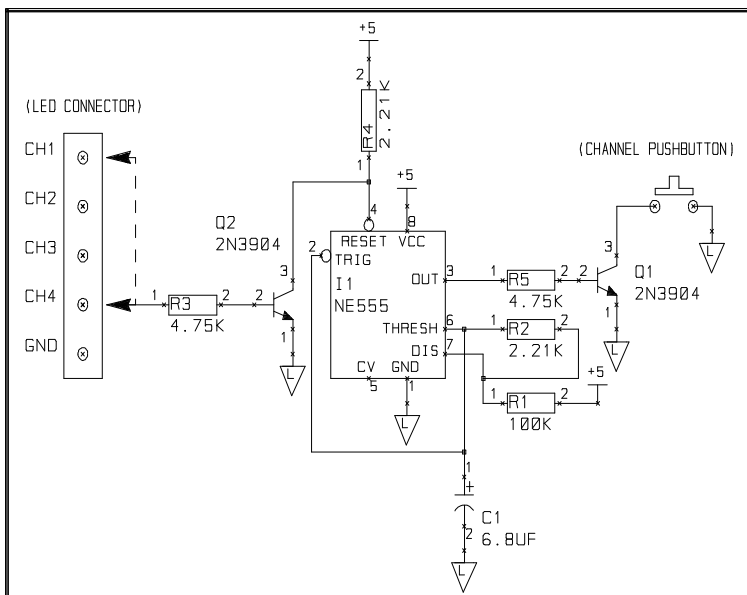



...Dale WB8CJW

## INBAND REPEATER IDEA!...Would anyone like to try this?

Check out the web site: <http://www.tapr.org/~n6gn/ocar/ocar.html>. This might be an answer for an inband ATV repeater where only one channel is available for ATV such as in Canada or within the A line, the second channel is used, or an existing repeater output can be extended over a hill or other obstacle. When not used for ATV it can be used for any mode much like a translator - GIGO.

Basically, the system is two isolated antennas with amplifiers and a filter between them. This *does* work! There has been a 10 GHz system working in San Diego for many months. While their block diagram shows a preamp driving a bandpass filter and then another amp, I don't think this will work at a commercial site with other transmitters. At commercial sites, in order to prevent front end overload and final amp intermod generation, I think it might be better to have a VSB filter driving a preamp into another VSB filter. The key to its operation is getting as much antenna to antenna isolation as possible and then setting the amplifier gain to about 10 dB less so that it does not turn into one big oscillator. Anyway, food for thought and might be worth some experimentation.

Only complication I can see is where does this fit within the FCC rules for attended or unattended operation and definition as to if it is a repeater or not since it does not retransmit on another frequency but rather as an auxiliary station.

...Tom O'Hara W6ORG tomsmb@aol.com

*Sounds like a great idea, Tom. This could be our answer for a Dayton-Columbus ATV link or for remote receive sites. It seems that it would work best at the higher frequencies (1250 MHz and up) because of the antenna gain/directivity attributes, so a dish would give the best front to back isolation. In any case, I hope that this sparks some experimentation among us. To that end, I have included below a more complete portion of the concept presented on the Internet. Further ideas are welcome!*

...Art WA8RMC.

### OCAR basics

The idea of on-channels repeaters is not a new one. In some ways OCARs are just an extension of the passive repeater which has been used for many years on microwave links to allow communications when the path between two stations is obstructed. Passive repeaters generally use large apertures, either a planar reflector or a pair of antennas, placed relatively close to one end of a radio link. They are positioned so as to intercept a significant fraction of the transmitted power from the nearer transmitter. That power is then either reflected directly (mirrorlike) or fed to a second antenna and directed toward the distant end of the link over a path which is much better than the direct path between the two end stations. Even though the losses over a path through a passive repeater are greater than those in freespace, these losses can be much less than what was possible over the original, obstructed path. If the apertures are big and close enough to catch significant power then communications can be maintained. Terrestrial microwave links sometimes use this technique to allow the placement of large and bulky antenna and electronics at ground level. The antenna points upward towards a planar reflector located nearby. A reflector of this type redirects the wavefronts to and from the ground mounted antenna and is actually a passive repeater. The reciprocity theorem says that this whole arrangement works in the reverse direction as well.

Active repeaters are an extension of this idea of "catching" power from one end of a link and redirecting it toward the other end. The active repeater does this by adding linear amplification between the "catching" antenna and the "focussing" antenna. This works as long as the isolation between the two repeater antennas is greater than the gain of the amplifier. If it is not, the system generally becomes an oscillator.

The technique has been used for one-way communication by commercial broadcasters to fill in shadowed areas of a customer base. In many situations, the output of the amplifier needs to be no more than a few watts.

Generally, the receive antenna is followed by a bandpass filter which in turn drives an output stage. The filter restricts operation to the channel or band of interest. It may be wide or narrow depending upon requirements. If very narrow filtering is required, it may be necessary to downconvert to a lower frequency where a suitable filter is more easily implemented and then re-convert back to the channel frequency. This arrangement is almost identical to the linear transponder of amateur satellites except for the lack of a frequency offset between the inbound and outbound signals. The similarity in acronyms between amateur OCARs and amateur OSCAR satellites is intentional.

For wideband modes, ATV or spread spectrum, it may be necessary to ensure that the group delay unflatness of the antennas, bandpass filter and amplifiers does not add unacceptable distortion to the signals of interest.

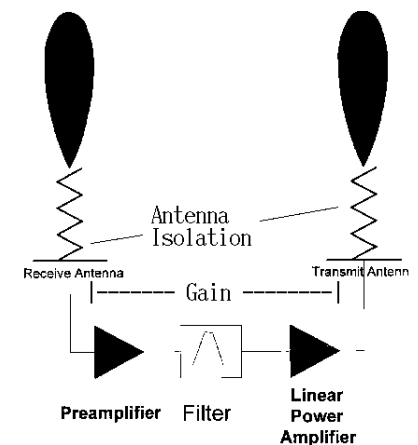

Isolation Between Antennas  $\gg$  Amplifier Gain + -10 dB

On-Channel Active Repeater (OCAR) Block Diagram

This idea has already been tried in the amateur world. Kerry Banke, N6IZW, has written an Update of what he and some of the San Diego Microwave Group have been doing at 10 GHz to help encourage a base of users who wouldn't otherwise be able to communicate due to obstructed radio paths.

Here in Northern California, we have also applied it at UHF. Our first OCAR is now running on 900 MHz and we hope to add another in the 1200 MHz band soon to allow two-way communications for both digital and analog systems by "fixing" paths.

OCARs have some nice attributes for amateur use:

- ❑ They can support many simultaneous users
- ❑ Simultaneous support of all modes of operation, SSB/CW, FM ,ATV or digital modes, including spread spectrum
- ❑ They are relatively simple and inexpensive to build, compared to conventional NBFM repeaters
- ❑ They can effectively put all users "on a hilltop" which can be a great boon to mutual support and enthusiasm in amateur radio experimentation, particularly on the higher frequency bands.
- ❑ When used in wireless digital networks they don't cause additional store & forward latency/delay don't require protocol or modulation/coding-specific hardware and software at a remote site.
- ❑ Eliminate the hidden-transmitter problem.
- ❑ OCARs can be cascaded to interconnect multiple user bases

### **Licensing and Regulatory Issues**

Because of the OCAR's similarity to a passive repeater, which for amateur uses does not need to be licensed, the regulations and requirements for it should not be too difficult. It can be argued that beyond 2\*OCAR\_range, any OCAR has less impact on the propagation in the EM spectrum than a passive reflector (though admittedly a very large one).

It's also worth noting that an OCAR is the same as a frequency translating repeater (like some OSCAR satellites) with zero frequency Offset.

Here in the US, the ARRL's Regulatory Information Specialist has already responded with the opinion that OCAR's meet one of the basic purposes of amateur radio; experimentation. The question of transmitter identification was raised and the opinion offered that as long as every user appropriately identified his station when using the OCAR that the terms of the license were met. If this isn't the case the OCAR should have its own identification method. Anyone wishing to experiment with OCARs should probably consult with their licensing body.

... <http://www.tapr.org/~n6gn/ocar/ocar.html>

---

### **NEWS FLASH...new ATV distance record**

Gentlemen: I just got word this afternoon that our ATNA European Regional Rep, Michel, HB9AFO and his colleagues in Europe have broken two world records on FSTV on 10 and 24 GHZ. After my translation, this is what he writes:

"Two ATV distance records have been battered during the ATV Expédition Corsica- Spain 1998:

New World Record for ATV on 10GHZ between TM2SHF (F1AAM, F1JSR, F5BUU and HB9DLH) located on the Col de Piana on the Island of Corsica in grid square JN42HF and EA5/HB9AFO/P (HB9ADJ, HB9AFO and SWL Jacky) located on Monte Pego in Spain in IM98XU. The distance is 821km or 510 miles (701km or 434 miles was the prior record). P5 strength signals were exchanged during more than 2 hours with power levels of 1 and 20 Watts with antennas between 2 ft (60cm) and 40 inches (1 meter).

European ATV Record on 24GHZ between TM2SHF in JN42HF, Corsica, and F/HB9AFO/P in JN23WE , Mont Caume, France. Distance: 248 km or 154 miles. QSO: 1 way with signal report P3/QSB. TM2SHF: Power 200mW, antenna 2.5 ft ( 75cm) to HB9AFO: DB6NT Converter, special feed, and 40 inch (1 meter) parabola.

The news in more detail and photos will be put on the Swiss ATV Internet Site of SWISS ATV <http://www.cmo.ch/swissatv> as soon as possible. Best 73,

Michel Vonlanthen, HB9AFO

6 July 1998"

...John Jaminet W3HMS (president ATNA)

## 2.4 GHZ ANTENNA DESIGN CONSIDERATIONS

A few of us have been experimenting with the Wavcom receivers and transmitters, others are still in the planning stage. In any case, the antenna to use is of utmost importance. The great advantage to working at this frequency is the very small antennas needed. So, it is possible to build even a more complex high gain antenna in an evening or two with materials obtained at the local hardware store at minimal cost. Many of us have the necessary materials in our "junk" boxes so hardware store trips are not needed. With that idea in mind, the only thing missing is what to build. I hope the information below helps you choose.

All of the antenna designs below are acceptable for monitoring our 2.4 GHz repeater output if you live within about a 15 mile radius and can obtain a line-of-sight path to the repeater. In fact, if that condition exists, a *dipole* could obtain a reasonable signal. However, experimentation is the name of the game so I'd like to see a number of antennas tried with reports as to which one was the best for your set of conditions. After all, I need material for the next newsletter but you knew that anyway. Be aware that all of the examples below except the helix antenna are vertically polarized to receive the ATCO repeater. If horizontal polarization is desired, the 1.12" dipole must be rotated 90 degrees. Okay! Start building!

**The coffee can antenna** is the basic antenna structure for most of the other antennas. Alone, this antenna exhibits a gain over a dipole of approximately 11 dB which in most cases, is enough to see the ATCO repeater P5 up to 15 miles away providing line of sight conditions exist. If 1/2" or 7/8" Heliac is used for the downfeed, there is no need to "mount" the can on anything. Simply anchor the Heliac and use the connection onto the Heliac be the mount. Note: extensive experimentation on my part has proved that Maxwell House coffee cans provide about 1/2 to 1 dB gain over other brands. I don't know why. Perhaps others will research this further and report their findings!

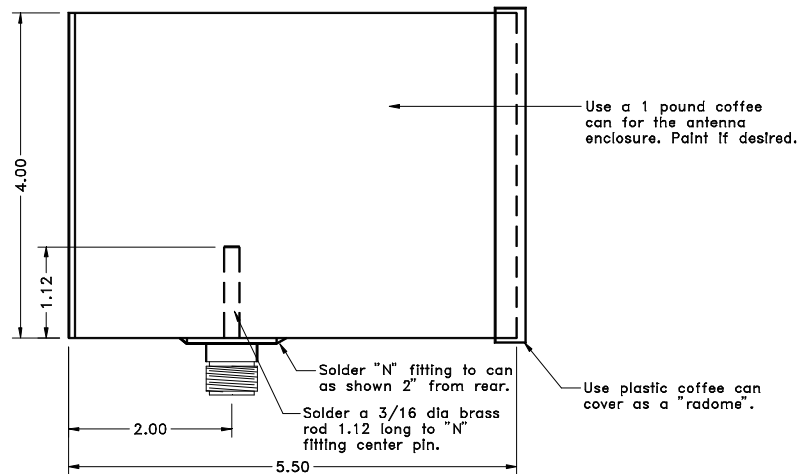

Construction is simple. Simply drill 1/2" hole in the can (for the 'N' fitting center conductor to pass through) 2" from the bottom. Drill a hole in the end of a 3/16" dia. x 1.12" long brass rod so the N fitting center conductor can be inserted and soldered. Solder the N fitting to the can. Mount the plastic cover on the can and you're finished!

**The funnel antenna** is simply a funnel, fabricated as shown at the right, and soldered to the open end of the coffee can antenna (remove plastic radome first). Use 1/4" or 1/2" hardware cloth available at hardware stores and form it into a funnel as shown for a throat diameter of 4" and an aperture of 16" with a length of 23".

The result produces another 6 dB or so of gain for a total of 16 - 17 dB.

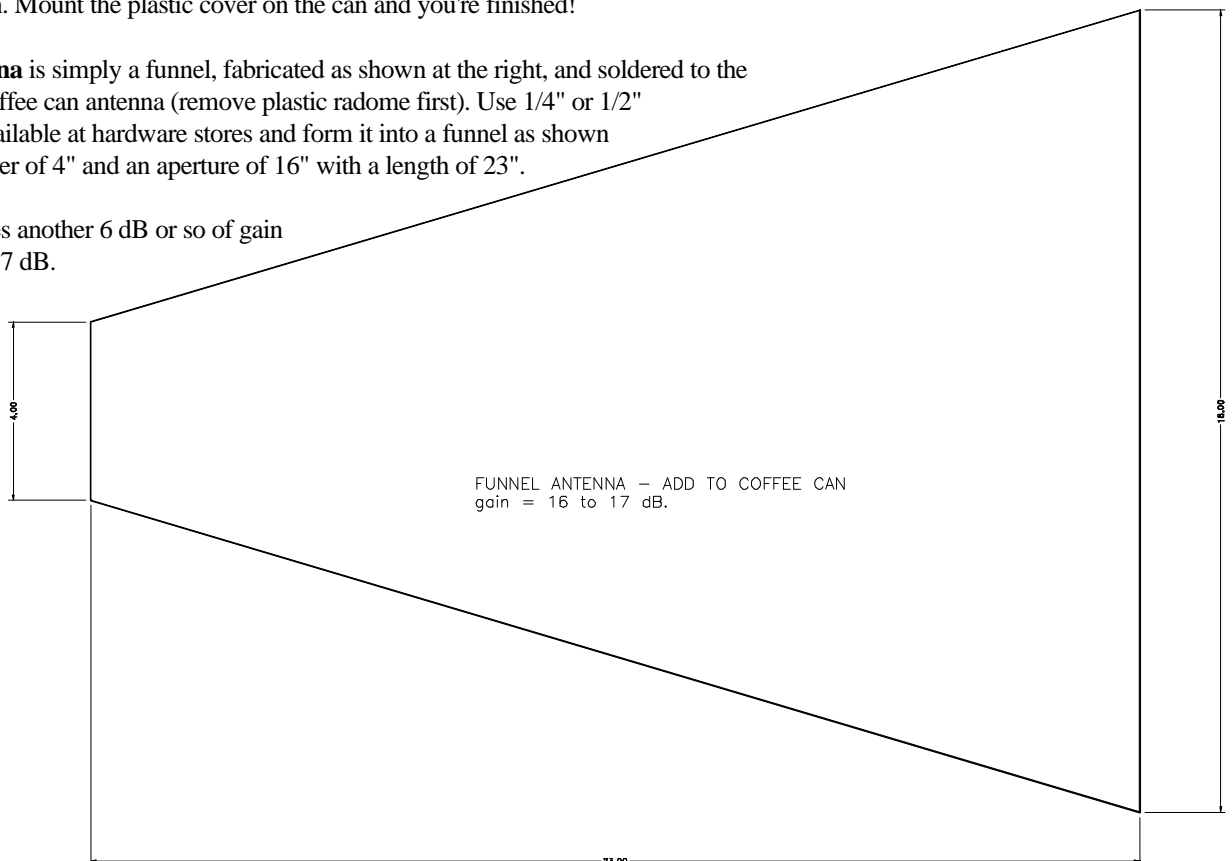

**The Cigar antenna** is also an extension of the coffee can antenna by adding spaced circular discs that serve as directors in front of the can. To do this, obtain a piece of 4" PVC pipe and a 4" PVC end cap. Mount the rod and disc assembly onto the cap. Then insert the cap into the section of pipe and slide the combination over the coffee can until a spacing of 1.75" is obtained from the first disc to the front edge of the open end of the coffee can.

The rod and disc assembly is made from a 1/4" dia. x 35" long steel or aluminum rod which spacers and discs are installed as shown below. Tighten the assembly when it's installed onto the PVC cap with 1/4" - 20 nuts. When assembled, the combination yields about 18 dB gain.

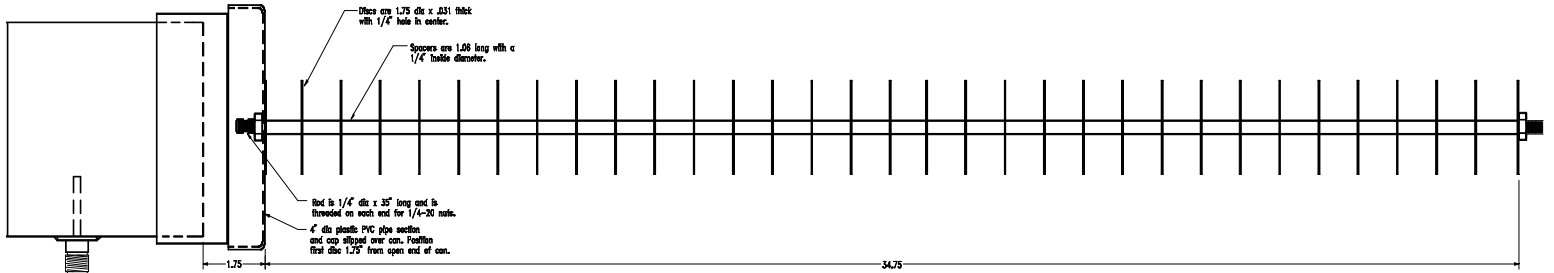

CIGAR ANTENNA  
gain = 18 dB.

**The parabolic antenna** gives the highest gain achievable. This one also uses the coffee can antenna with the open end pointing toward the dish. Many types and styles of parabolic dishes can be used here so dimensional data is left to the builder. The UHF 4 foot diameter antennas are excellent and result in about 23 dB of gain. The distance from coffee can open end edge to the parabolic surface will vary from dish to dish but will generally be about 23". You must experiment by adjusting it a couple of inches either way to obtain maximum signal.

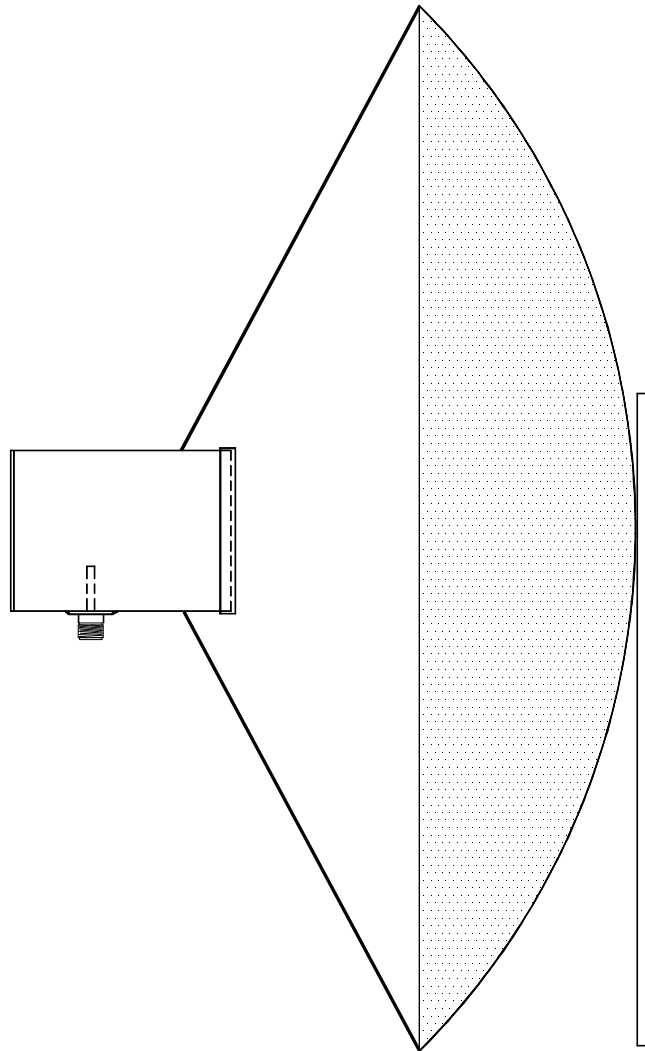

**The garbage can antenna** uses a metal garbage can lid as the reflector instead of a parabola. The coffee can is attached to the garbage can lid with a piece of 4" PVC pipe and end cap similar to the cigar antenna above but it could also be supported like the parabolic antenna above...designer choice. Again the focal length will depend upon the lid but should be around 10 to 12" from lid to coffee can open end.

As an alternative to the garbage can lid, you might also try a metal 26" diameter round snow sled. Again the focal distance is around 10" to coffee can open end.

Both of the above two examples yield about 18 dB of gain.

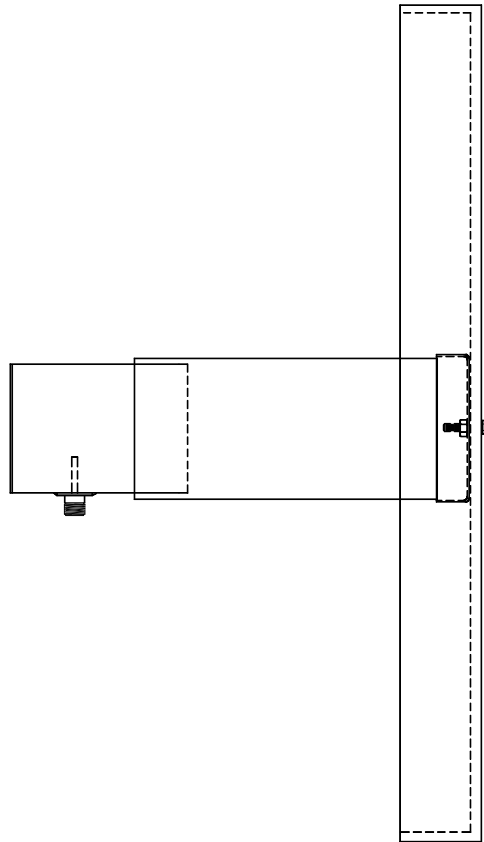

**The Helix antenna** is the last presented here. It is unique because the polarization is circular which will respond to both horizontally and vertically transmitted signals equally with about a 3 dB reduction from a circularly polarized transmitted signal. Therefore the overall gain from a circularly polarized signal is about 15 dB and 12 dB from either a vertical or horizontal signal. The great advantage here is that the commercial remote to transmitter links and remote feed horizontally polarized signals and the repeater output can be viewed equally.

The antenna consists of 17 turns of #10 copper wire wound on a 1.75" diameter PVC tube. Each turn is spaced about 1.25" as shown with the far end being inserted into a tight fitting hole in the PVC tube. It would be a good idea to lacquer the wire and tube to prevent the wire from shifting. The reflector plate is a 7" square sheet of aluminum plate or other conductive surface so the N fitting can be mounted to it.

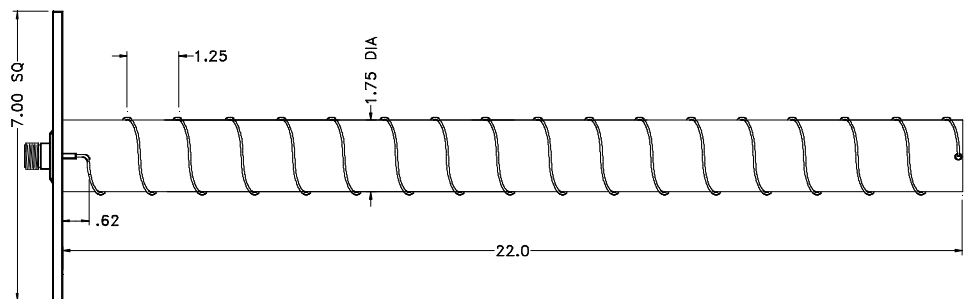

## ATCO 1998 SPRING EVENT MINUTES

### Attendees

STATION CALL	NAME	STATION CALL	NAME
WA3DTO	RICK WHITE	W8PGP	DICK BURGGRAF
KB8WBK	DAVID HUNTER	WB8CJW	DALE ELSHOFF
K8KQN	TED POST	KE9SX	FRANK WOODCOX
?	THOMAS SMITH	WA8HFK	FRANK AMORE
KC8HIP	PAT AMORE	KA8ZNY	TOM TAFT
KB8YMQ	JAY CALDWELL	W8RVH	DICK GOODE
WA8SJV	JOHN BEAL	KB8SLQ	DAN BEAL
WA8RMC	ART TOWSLEE	KE8PN	JIM EASLEY
WA8DNI	JOHN BUSIC		MURRY MERCIER
WB8DZW	ROGER McELDOWNEY	N8TBU	ED LATHAM
KF8QU	BOB TOURNOUX	KB8UU	BILL ROSE
	TERRY LUCARELLI	WA8RUT	KEN MORRIS

After a great lunch funded by ATCO and provided by WA3DTO, ATCO was called to order at 2:00 PM, Sunday, May 3, 1998 with opening comments made by WA3DTO and WA8RMC. All guests introduced themselves.

### The topics discussed are as follows:

- Murry Mercier was invited at this time to present information on the early attempts to broadcast television. The year was 1928 and broadcasting was performed in the MF band at around 800 kHz. The efforts centered around a flying spot scanner for reception of a signal as initially broadcast by General Electric in Schenactady, NY, on the call letters WGY. Additional broadcasts were from WPDI Columbus, OH, and W8XK (ic) Washington, DC.
- WA8RMC then discussed the repeater noting that 2.4 GHz was up and running on the transmit side at approximately 10 watts. WA8RUT explained the types of antennas to be used for reception and the type of transmit antenna being used.
- For those that have WaveCom's, reception is on channel 1. Future transmit link frequency will be Channel 4 or 2410 MHz.
- **Amateur Television Group of North America:** This is going to be the new national television group in the United States and North America. The acronym will be "**ATNA**". Art, WA8RMC has been appointed Vice President of the organization for Membership.
- The Friday Night ATV get together will be held once again at the Lion's Club in West Carrollton, Ohio. All interested should attend. There will be many topics of discussion including ATNA. At this time, Art, WA8RMC motioned to send John, W8STB, \$75, to help defray costs of the meeting. Tom Taft, KA8ZNY, put a first and Jay, KB8YMQ responded with a second. All agreed.
- WA8RUT has been "chosen" as the coordination chairman on behalf of Ohio ATV Groups for frequency allocations. The discussion led to interference with the Xenia repeater when the 70 CM output was changed from 427 to 421 MHz. All agreed the picture was better at 421. For now, the repeater output will be changed back to 427 to eliminate any interference to Xenia. It is even questionable if we interfere with the Xenia repeater and ATCO may have the right to use 421 MHz as its output.
- Ken will work with the Ohio repeater council on the ATV frequency allocation issue in general. There have been 5 zones designated for Ohio and ATCO is in zone 5.
- The new Kenwood SSTV system was briefly mentioned and was rumored to be introduced at Dayton this year.
- Art then asked if there were any members (or guests that would like to become a member) to pay dues at this time.
- New filters have been added to both sides of the receive and transmit signals.
- Election of officers was brought to the floor with a motion by Art, WA8RMC, to table the elections until the last meeting of the calendar year. Roger, WB8DZW, offered a first on the motion with John, WA8DNI, offering a second on the motion. All agreed.
- A brief discussion opened up on a potential Columbus to Dayton ATV link with the link repeater to be in the Belfontaine area.
- Art, WA8RMC then asked what new features would be welcomed for the repeater or the club in general.
- Everyone welcomes the 2.4 GHz movement for ATV and continued interest in public service events.
- Silent Keys: K8AOH and N8CYV
- Show and Tell: Dick Goode, W8RVH, showed a 1200 MHz transmitter and the ease in which to build one.  
Art, WA8RMC showed the new GEKCO Labs RGB, Bar/Dot, Cross Hatch Generator.

The meeting was officially ended at 3:10 PM.



---

## NEW MEMBER SECTION

Let's welcome the new members to our group! If any of you know anyone who might be interested, let one of us know so we can flood them with information. New members are the lifeblood of our group so it's important that we actively recruit new faces aggressively.

KS4GL John Barnes Lexington, Ky.

WA8SJV John Beal Columbus, Ohio

WA8HFK, KC8HIP Frank and Pat Amore Hilliard, Ohio

KB8FF Dave Tkach Columbus, Ohio

KC8BNI Fred Stutske Pickerington, Ohio

---

## HAMFEST CALENDAR

This section is reserved for upcoming hamfests for as far in advance as we know about them. They are limited to Ohio and vicinity easily accessible in one day. Anyone aware of an event incorrectly or not listed here notify me so it can be corrected. I maintain some fliers that compile this list so for additional info Email me at [towslee@ee.net](mailto:towslee@ee.net). This list will be amended as further information becomes available.

November 14-15...Fort Wayne, Ohio..Allen County War Memorial Coliseum Expo Center 146.88-

July 12 Wood County ARC, Bowling Green, OH John Lagger, AA8XS 7234 Latcha Rd., Perrysburg, OH 43551 419-666-5939

July 18 Northern Ohio ARS, Wellington, OH John Schaaf, KC8AOX PO Box 432, Elyria, OH 44036-0432 216-696-5709

July 19 Van Wert ARC, Van Wert, OH Louie Thomas, WD8LLO 208 North Chestnut St., Van Wert, OH 45891 419-238-2812

July 25 OH-KY-IN ARS, Cincinnati, OH Dana Laurie, WA8M 280 Hillcrest Dr., Cincinnati, OH 45215-2610 513-761-7388

July 26 Paulding County AR Group, Paulding, OH Jerry Rhodes, KB8MAF PO Box 86, Paulding, OH 45879 419-399-4507

August 1 Voice of Aladdin ARC, Columbus, OH Jim Morton, KB8KPJ 6070 Northgap Dr., Columbus, OH 43229-1945 614-846-7790

August 2 Portage ARC, Randolph, OH Joanne Solak, KJ3O 9971 Diagonal Rd., Mantua, OH 44255 330-274-8240

August 16 Warren ARA, Warren, OH Charles Solinger, N8HRZ 722 Scott Ave., Niles, OH 44446 330-652-5028

September 13 Findlay Radio Club, Findlay, OH Dave Hoxworth, AA8KJ PO Box 587, Findlay, OH 45839 419-423-3402

September 20 Greater Cincinnati ARA, Cincinnati, OH Jim Weaver, K8JE 11652 Hollingsworth Way, Forest Park, OH 45240-2516

September 27 Hamfest Association of Cleveland, Cleveland, OH William Beckman, N8LXY 1-800-CLE-FEST 216-999-7388

September 27 Independent Radio Assn., Springfield, OH David Ray, KC8BVM 937-325-3047

October 11 Northwest Ohio ARC, Lima, OH Greg Schwark, N8WBD 600 Sunset Dr., Spencerville, OH 45887-1259 419-647-6321

October 25 Marion ARC, Marion, OH Karen Eckard, N8KE 6583 South Street Meeker, Marion, OH 43302 614-499-3565

November 1 Massillon ARC, Massillon, OH Don Wade, W8DEA 7300 Sunset Strip, A-7, North Canton, OH 44720 330-497-7232

November 14-15 Fort Wayne, IN Doug Jones, N9NNT & Jim Boyer, KB9IH PO Box 10342, Fort Wayne, IN 46851 219-484-3317

---

## ANTENNA PARTY - BEER - ANTENNA PARTY - BEER - ANTENNA PARTY - BEER

It is our honor that Ted, N8KQN, has invited us into his backyard on Saturday August 22 for our 9<sup>st</sup> annual antenna measurement and socializing party. We have had these events in the past, and if you remember *way back*, you'll remember the good times we had out at Chuck Beener's (WB8LGA) place in the country. Just recently we had an antenna party in conjunction with the Fall Event. That one didn't work very well mainly because there wasn't enough time to carry on event activities and measure antennas also! So this time we'll try it as a solo event. Ed has a very large back yard so space shouldn't be a problem.

Bring your favorite antenna and see how much gain (or loss) it has... for the fun of it or for competition. We'll try to work up prizes for different categories. Suggestions: highest gain, lowest gain, most unusual, or whatever. Talk it up on our Tuesday night net as to the categories. I will have the antenna plotting equipment for 439 MHz, 1280 MHz and maybe 2433 MHz with a printer so you can have a plotted record of your accomplishment.

What if you don't have an antenna to bring or just don't want to know how bad it really is? No problem! Come and watch the action and maybe pick up a few pointers about antenna construction. Not interested in that either? OK then, **just come and drink the beer**. In any case, join us on the 22<sup>nd</sup> and help to make this event one of many in the future.

...Art WA8RMC

## ATV EQUIPMENT SUPPLIERS

Below is a list of manufacturers of ATV equipment that I have found. There is no endorsement of any of the manufacturers listed below so buyer beware. If I or anyone else that I know of, has had any trouble with a manufacturer, it won't be listed. As I get more info, I'll add manufacturers. Likewise, if I hear of any trouble, it'll be removed. Good luck and keep me advised. WA8RMC

### Michael Kohlstadt, KD6UJS

has a limited supply of used but working Pacific Monolithics 2.4ghz downconverters and power supplies which will work fine for viewing the repeater.

Phone: 408-926-0430.

### Down East Microwave

Antennas, Power Amplifiers, Deluxe Downconverters, microwave parts.

954 Rt. 519 Frenchtown, NJ 08825

Phone: 908-996-3584

Fax: 908-996-3702

### HF Technologies Inc.

FMTV Transmitters, Receivers

457 Santa Fe Trail

Cary, IL 60013

Phone: 708-639-4336

### PC Electronics

ATV Transmitters, Receivers Manufacturer/Reseller

2522 Paxson Ln.

Arcadia, CA 91009-8537

Phone: 626-447-4565

Fax: 818-447-0489

tom@hamtv.com

www.hamtv.com

### Phillips-Tech Electronics

MMDS, ITFS downconverters and antenna systems

P.O. Box 8533

Scottsdale, AZ 85252

Phone: 602-947-7700

Fax: 602-947-7799

### R. Myers Communications

Good, single unit, source for 2.4GHz dishes

P.O. Box 17108

Fountain Hills, AZ 85269-7108

Phone: 602-837-6492

Fax: 602-837-6872

### SHF Microwave Parts Company

10GHz Gunn oscillators and Antennas

7102 W. 500 S.

LA PORTE, INDIANA, 46350

Fax: 219-785-4552

### Wyman Research Inc.

FMTV Transmitters, Receivers

Box 95, RR 1

Waldron, IN 46162

Phone: 765-525-6452

### DCI Communications

Interdigital filters and cavities

Box 293, 29 Hummingbird Bay

White City, SK, Canada S0G5B0

Phone: 306-781-4451

### ATV Research Inc.

TV cameras & related parts

1301 Broadway PO Box 620

Dakota City, NE 68731-0620

Phone: 402-987-3771

Homepage: [www.atvresearch.com](http://www.atvresearch.com)

Email: atc@pionet.net

### GEKCO Inc

TV test signal circuit boards

PO Box 642

Issaquah, Wa 98027-0642

Phone: 425-392-0638

Email: [sales@gekco.com](mailto:sales@gekco.com)

Homepage: [www.gekco.com](http://www.gekco.com)

### M2

Antennas

7560 N. Del Mar Ave.

Fresno, Ca 93711

Phone: 209-432-8873

### ATV Quarterly (ATVQ)

ATV magazine publisher

5931 Alma Drive

Rockford, Il. 61108

Phone 815-398-2683

FAX 815-398-2688

Email: atvq@aol.com

<http://www.cris.com/~Gharlan>

### Spectrum International

J-Beams, KVG, Micromodules, VSB filters

John Beanland

Phone: 978-263-2145.

Email: [Spectrum@ma.ultranet.com](mailto:Spectrum@ma.ultranet.com)

**Note:** Additional commercial vendors may be viewed on the Internet at <http://bro.net/explorer/vendor.html>.

---

## INTERNET INFO

If you have access to the INTERNET, you may be interested to know of some of the HAM related information that is available. Most addresses listed below are case sensitive, so type exactly as shown below. (If anyone has comments or would like additional listings contact me via Email at [towslee@ee.net](mailto:towslee@ee.net)).

<http://psycho.psy.ohio-state.edu/atco>  
[http://www.bright.net/~rmeeksjr/atv\\_day.htm](http://www.bright.net/~rmeeksjr/atv_day.htm)  
<http://fly.hiwaay.net/~bbrown/index.htm>  
WB8ELK)  
<http://www.netbox.hayden.edu/Guests/AATV>  
<http://www.citynight.com/atv>  
<http://www.ladas.com/ATN>  
<http://w6yx.stanford.edu/~stevem/atv>  
<http://www.qsl.net/wb6izg>  
<http://home1.gte/k4lk>  
<http://www.mindspring.com/~rwf/aatn1.html>  
<http://ww2.netnitco.net/users/stealth/kens.htm>  
<http://www.smart.net/~brats>  
<http://www.murphysoftware.com/dats>  
<http://www.njin.net/~magliaco/atv.html>  
<http://www.intercenter.net/triatv/atv-web.htm>  
<http://www.navicom.com/~satva/satvainf.htm>  
<http://www.lloydio.com/oatva.html>  
<http://wwwwebczar.com/atv>  
<http://members.aol.com/n3kkm/w3hzu.html>  
<http://www.usaor.net/users/ka3fzf/index.htm>  
<http://www.voicenet.com/~theojkat/w3phl.html>  
<http://www.geocities.com/Hollywood/5842>  
<http://www.stevens.com/HATS/home.html>  
[http://uugate.aim.utah.edu/utah\\_atv/root.html](http://uugate.aim.utah.edu/utah_atv/root.html)  
<http://www.bchfs.org/metrovision/atv.htm>  
<http://www.qsl.net/w7twu>  
<http://scott-inc.com/wb9neq.htm>  
<http://www.premiernet.net/~hcantrl/>  
<http://www.ecn.net.au/~sbloxham/index.html>  
<http://ourworld.compuserve.com/homepages/batc>  
<http://www.sfn.saskatoon.sk.ca/recreation/hamburg/hamatv.html> Saskatoon, Canada ATV  
<http://www.gpfn.sk.ca/hobbies/rara/atv3.html>  
<http://www.inside.co.uk/scart.htm>  
<http://www.emo.ch/swissatv>

ATCO ATV home page.  
Ohio, Dayton ATV group  
Alabama, Huntsville, Tennessee Valley ATV (Bill Brown  
Arizona, Phoenix Amateurs  
California, San Francisco ATV  
California, Amateur Television Network in Central / Southern  
California, South Bay ATV Group Stanford University  
California, southern ATV Sights and Sounds  
Florida, Tampa Bay ATV Society (TBATS)  
Georgia, Atlanta ATV  
Indiana KB9I homepage  
Maryland, Baltimore Radio Amateur Television Society (BRATS)  
Michigan, Detroit DATS ATV  
New Jersey, Brookdale ARC in Lincroft  
N. Carolina, Raleigh. Triangle ATV club  
Oregon, Silverton, Salem ATV Assoc (SATVA)  
Oregon, Portland ATV (OATVA)  
Oklahoma, Tulsa Amateur TV (TARC)  
Pennsylvania, York Keystone VHF Club  
Pennsylvania, Pittsburg Amateur Television in Pittsburg  
Pennsylvania, Phila. Area ATV  
Tennessee, East ATV  
Texas, Houston ATV  
Utah ATV  
Virginia, Alexandria  
Washington, Western Washington Television Society (WWATS)  
Airborn ATV from WB9NEQ in Bowling Green, Kentucky  
Kentucky, Bowling Green (CKATS)  
Australia, ATV, VK4GY (large list of other ATV & ham radio sites)  
British ATV club (BATC)  
Saskatoon, Canada ATV  
Regina, Canada ATV  
UK, Great Britain ATV (SCART)  
Swiss ATV

NOTE: If you're a regular Internet browser, maybe you'd like to be kept up to date on all of the ATV related news generated Nationally. If so, subscribe to the "ATV Internet mailing list" to receive the bulletins automatically. If you'd like to SEND a message to all other subscribers this can be done also. It's free to all. To *subscribe*, send Email to "listserv@tallahassee.net" and include in the message the line SUBSCRIBE ATV. To *send a message* address it to "ATV@tallahassee.net". To be *removed* from list, send Email to "listserv@tallahassee.net" and include in the message "UNSUBSCRIBE ATV".

The following addresses are helpful in searching for many different Ham Radio items on the INTERNET.

<http://www.cris.com/~Gharlan>  
<http://www.hamtv.com>  
<http://downeastmicrowave.com>  
[http://www.yahoo.com/Entertainment/television/Amateur\\_television](http://www.yahoo.com/Entertainment/television/Amateur_television) Listing of some of the available ATV home pages.  
<http://www.acs.ncsu.edu/HamRadio>  
<http://www.arrrl.org/hamfests.html>  
<http://amsat.org>  
<http://www.arrrl.org>  
<http://www.ualr.edu/doc/hamualr/callsign.html>  
<http://hamradio-online.com>

ATVQ Magazine home page. ATV equipment & article references.  
PC Electronics Inc. Lots of proven ATV equipment for sale.  
Down East Microwave Inc. Lots of uhf/microwave parts & modules.  
General ham radio info- satellite track, call sign database etc.  
Current yearly hamfest directory.  
AMSAT satellite directory/home page.  
ARRL home page  
Search by call sign or name.  
Ham Radio Online "newsletter" Lot of Ham related information.



## ATCO REPEATER TECHNICAL DATA SUMMARY

This space of each publication includes the technical information of our repeater. Each time a new feature is brought on line it's added here. Use this as a quick reference for up/down access codes as well as some of the more important parameters of our system.

**Main repeater:** Location: Downtown Columbus, Ohio

Coordinates: 82 degrees 59 minutes 53 seconds (longitude)  
39 degrees 57 minutes 45 seconds (latitude)

Elevation: 630 feet above average street level  
1460 feet above sea level

Transmitters: 427.25 MHz AM modulation, 1250 MHz FM modulation and 2433 MHz FM modulation.  
interdigital filters in output line of 427.25 & 1250 transmitters  
Transmitter Output Power - 40 watts average 80 watts sync tip (427.25)  
50 watts continuous (1250)  
8 watts continuous (2433)  
Link transmitter - 1 watt NFM 5 kHz audio (446.350 MHz)

Identification Both 427, 1250 and 2433 transmitters identify simultaneously every 10 minutes with video showing ATCO and WA8RUT with four different screens. Audio identification is 4 sequences of Morse Code.

Transmit antenna: 427.25 MHz - Dual slot horizontally polarized 7 dBd gain major lobe west  
1250 MHz - Diamond vertically polarized 12 dBd gain omni  
2433 MHz - Comet vertically polarized 12 dBd gain omni

Receivers: 147.45 MHz for F1 audio input control of touch tones  
439.25 MHz for A5 video input with FM subcarrier audio (lower sideband)  
915 MHz for F5 video link data from remote sites  
1280 MHz for F5 video input

Receive antennas: 147.45 MHz - Vert. polar. Hi Gain "Comet" 12 dBd (also for 446 MHz output)  
439.25 MHz - Horiz. polar. dual slot 8 dBd gain major lobe west  
915 MHz - Vert. polar. dB Products 10 dBd gain  
1280 MHz - Horiz. polar. single slot 3 dBd gain major lobe west.

		<u>UP</u>	<u>DOWN</u>
Input control:	Major Touch tones: beacon (5 min)	*439	*22
	regional weather radar	697	#
	Local radar(5 min)	264	#
	User repeat 1 minute	*45	*22
	Touch tone pad tester	#0	#5
	Manual mode (ID)	*77 90	*22
	(910 input)	*77 91	*22
	(439 input)	*77 92	*22
	(1280 input)	*77 93	*22
	(future)	*77 94	*22
	5 second ID	#9	*22
	Bulletin board	285 pause 92	286
	Roof Camera	285 pause 95	286
Reset to scan mode	D37 or #437		

Remote sites: Local radar (inactive at this time) (915 MHz link output 8 watts)  
Aux link at WA8RUT QTH (915 MHz link output 1 watt)  
Aux link at WB8CJW QTH (915 MHz link output 1 watt)

---

## ATCO MEMBERSHIP INFORMATION

Membership in ATCO (Amateur Television in Central Ohio) is open to any licensed radio amateur who has an interest in amateur television. The annual dues are \$10.00 per person payable on January 1 of each year. Additional members within an immediate family and at the same address are included at no extra cost.

ATCO publishes the ATCO newsletter quarterly in January, April, July, and October. The newsletter is sent to each member without additional cost.

The membership period is from January 1<sup>ST</sup> to December 31<sup>ST</sup>. New Members will receive all ATCO newsletters published during the current year prior to the date they join ATCO. For example, a new member joining in June will receive the January and April issues in addition to the July and October issues. Your support of ATCO is welcomed and encouraged.

---

## ATCO CLUB OFFICERS

President: Art Towslee WA8RMC	Repeater trustees: Art Towslee WA8RMC
V.President: Ken Morris WA8RUT	Ken Morris WA8RUT
Treasurer: Bob Tournoux KF8QU	Dale Elshoff WB8CJW
Secretary: Rick White WA3DTO	Statutory agent: Rick White WA3DTO
Corporate trustees: Same as officers	Newsletter editor: Art Towslee WA8RMC

---

## ATCO MEMBERSHIP APPLICATION

RENEWAL  NEW MEMBER  DATE \_\_\_\_\_ CALL \_\_\_\_\_

OK TO PUBLISH PHONE # IN NEWSLETTER YES  NO  HOME PHONE \_\_\_\_\_

NAME \_\_\_\_\_ INTERNET \_\_\_\_\_ Email \_\_\_\_\_

ADDRESS \_\_\_\_\_

ADDRESS \_\_\_\_\_

CITY \_\_\_\_\_ STATE \_\_\_\_\_ ZIP \_\_\_\_\_

FCC LICENSED OPERATORS IN THE IMMEDIATE FAMILY \_\_\_\_\_

COMMENTS \_\_\_\_\_

\_\_\_\_\_

ANNUAL DUES PAYMENT OF \$10.00 ENCLOSED CHECK  MONEY ORDER

Make check payable to ATCO or Bob Tournoux & mail to: Bob Tournoux KF8QU 3569 Oarlock CT Hilliard, Ohio 43026

**TUESDAY**

---

## NITE NET ON 147.45 MHz SIMPLEX

Every Tuesday night @ 9:00PM WA8RMC hosts a net for the purpose of ATV topic discussion. There is no need to belong to the club to participate, only a genuine interest in ATV. All are invited. For those who would like to check in, the general rules are as follows: Out-of-town and video check-ins have priority. A list of available check-ins is taken first then a roundtable discussion is hosted by WA8RMC. After all participants have been heard, WA8RMC will give status and news if any. Then a second round follows with periodic checks for late check-ins. We rarely chat for more than one hour so please join us if you can.

**ATCO**

---

## TREASURER'S REPORT - de KF8QU

OPENING BALANCE (4/10/98).....	\$ 751.85
RECEIPTS (dues).....	\$ 170.00
(donation for Wavecom sales).....	\$ 20.00
OTHER INCOME (bank interest).....	\$ 4.96
EXPENDITURES	
(food for spring event).....	\$ 173.93
(Postage for April Newsletter).....	\$ 35.75
(donation to Friday Nite party).....	\$ 75.00
CLOSING BALANCE (7/12/98).....	\$ 662.13

## ATCO MEMBERS AS OF 12 JULY 1998

				*email*
K8AEH	Wilbur Wollerman	1672 Rosehill Road	Reynoldsburg	Oh 43068 866-1399
WB4BBF	Randall Hash	212 Long Street	Bluefield	Va 24605
W4/F5BJV	Marcel Pitzini	443 Eastland Drive	Decatur	Ga 30030 404-378-2772
KC8BNI	Fred Stutske	8737 Ashford Lane	Pickerington	Oh 43147 kc8bni@amsat.org
KC8CNV	Jack Compson	5065 Sharon Hill Dr	Columbus	Oh 43235 451-4054
WB8CJW	Dale Elshoff	8904 Winoak Pl	Powell	Oh 43065 766-5823 dale.elshoff@usiny.mail.abb.com
WA8DNI	John Busic	2700 Bixby Road	Groveport	Oh 43125 491-8198 wa8dni@juno.com
K8DW	Dave Wagner	2045 Maginnis Rd	Oregon	Oh 42616 419- 691-1625
WA4DFS	Ed Walker	PO Box 150	Mountain City	Tn 37683 423- 727-9611 ebwalker@preferred.com
WA3DTP	Rick White	5314 Grosbeak Glen	Orient	Oh 43146 877-0652 wa3dto@aol.com
WB8DZW	Roger McEldowney	5420 Madison St	Hilliard	Oh 43026 876-6033 wb8dzw@aol.com
W8EHW	Foster Warren	P.O. Box #32	No. Hampton	Oh 45349
KB8FF	Dave Tkach	2063 Torchwood Loop S	Columbus	Oh 43229 882-0771 tkack@copper.net
KS4GL	John Barnes	216 Hillsboro Ave	Lexington	Ky 40511 606-253-1178 ks4gl@juno.com
WD4GSM	E.R. Hall	4955 Pole Bridge Rd	Wise	Va 24293 540- 328-9235
K6GUC	Reuben Meeks	428 Lewiston Road	Kettering	Oh 45429 937- 294-0575
KA8HAK	Jim Reese	1106 Tonawanda Ave	Akron	Oh 44305
WA8HFK,KC8HIP	Frank, Pat Amore	3630 Dayspring Dr	Hilliard	Oh 43026 777-4621
W8JND	Richard Knowles	573 Plaza Drive	Circleville	Oh 43113 477-8132
N8KQN	Ted Post	1267 Richter Rd	Columbus	Oh 43223 276-1820
WA8KQQ	Dale Waymire	225 Riffle Ave	Greenville	Oh 45331 513- 548-2492
K8MBY,N8SIR,KB8UVK	Phil,Jim,Phil jr Buckholdt	153 East Bergey St	Wadsworth	Oh 44281
N8LRG	Phillip Humphries	3226 Deerpath Drive	Grove City	Oh 43123 871-0751 phumphries@iwaynet.net
KA8MID	Bill Dean	2630 Green Ridge Rd	Peebles	Oh 45660 deanfam@bright.net
KB8MDE	Shaun Miller	5061 County Rd 123	Mt Gilead	Oh 43338 419- 768-2588 kb8mde@bright.net
K8MZH	Leland Hubbell	7706 Green Mill Road	Johnstown	Oh 43031 967-8412
WD8OBT,KB8ESR,KA8ZPE	Tom Camm & sons	1634 Dundee Court	Columbus	Oh 43227 860-9807
N8OCQ	Robert Hodge	3689 Hollowcrest	Columbus	Oh 43223 875-7067
N8OOA	Jeff Clark	9894 Fincastle-Winchester	Sardinia	Oh 45171 937- 695-1229
N8OPB	Chris Huhn	146 South Hague Ave	Columbus	Oh 43204 279-7577
W6ORG	Tom O'Hara & family	2522 Paxson Lane	Arcadia	Ca 91007 626- 447-4565 tom@hamtv.com
WB8OTH	Perry Yantis	1850 Lisle Ave	Obetz	Oh 43207 491-1498 pyantis@compuserve.com
WA2PCH	Craig Stoll	PO box 1117	Orchard Park	Ny 14127
KE8PN	James Easley	1507 Michigan Ave	Columbus	Oh 43201 421-1492 jeasley@ee.net
W8PGP,WD8BGG	Richard, Roger Burggraf	5701 Winchester So. Rd	Stoutsville	Oh 43154 614- 474-3884
KF8QU	Bob Tournoux	3569 Oarlock Ct	Hilliard	Oh 43026 876-2127 rtournou@columbus.rr.com
W8RIK	Joe Hussey	1678 Sandhurst Rd	Columbus	Oh 43229 895-7601
WA8RMC	Art Towslee	180 Fairdale Ave	Westerville	Oh 43081 891-9273 towslee@ee.net
WA8RUT,N8KCB	Ken & Chris Morris	3181 Gerbert Rd	Columbus	Oh 43224 261-8583 wa8rut@aol.com
W8RVH	Richard Goode	9391 Ballentine Rd	New Carlisle	Oh 45334 513- 964-1185 w8rvh@glasscity.net
WD8RXX	John Perone	3477 Africa Road	Galena	Oh 43021
WA8SAR	Gary Obee	3691 Chamberlain	Lambertville	Mi 48144
N8SFC	Larry Campbell	316 Eastcreek Dr	Galloway	Oh 43119 851-0223 larry@psycho.psy.ohio-state.edu
WA8SJV	John Beal	2899 Castlebrook Ave	Columbus	Oh 43026 876-9412
W8STB	John Hey & family	894 Cherry Blossom Dr	West Carrollton	Oh 45449 937- 859-5295 w8stb@megsinet.com
N8TBU	Ed Latham	8399 Fairbrook Ave	Galloway	Oh 43119
KB8TRP,KB8TCF	Tom, Ed Flanagan	1751 N. Eastfield Dr	Columbus	Oh 43223 272-5784 eflanagan@ohlck.ang.af.mil
WA8TTE	Phil Morrison	154 Llewellyn Ave	Westerville	Oh 43081
KB8UGH	Steve Caruso	39 South Garfield Ave	Columbus	Oh 43205 461-5397 scaruso@freenet.columbus.oh.us
WB8URI	William Heiden	4435 Kaufman Rd	Plain City	Oh 43064 614- 873-4402
KB8UU	Bill Rose	9250 Roberts Road	West Jefferson	Oh 43162 879-7482
WB8VJD	Rick Morris	203 Merton Street	Holland	Oh 43528
KA8VUQ	Jack Wolff	2682 Hiawatha Ave	Columbus	Oh 43212 263-3092
W8WAU	Jake Fuller	PO Box 117	No. Hampton	Oh 45349
N8WLT	James Neymeyer	2879 East Moreland Drive	Columbus	Oh 43209 237-2331
KB8WBK	David Hunter	45 Sheppard Dr	Pataskala	Oh 43062 927-3883 dhunter147@aol.com
N8XYJ	Dan Baughman	4269 Hanging Rock Ct	Gahanna	Oh 43230 471-1089
KB8YIO	Ric Wise	1465 25 <sup>th</sup> Ave	Columbus	Oh 43211 291-6508 kb8yio@iwaynet.net
KB8YMN	Mark Griggs	2160 Autumn Place	Columbus	Oh 43223 272-8266 mmgriggs@aol.com
KB8YMQ	Jay Caldwell	4740 Timmons Dr	Plain City	Oh 43064
KB8ZLB	Dave Kibler	243 Dwyer Rd	Greenfield	Oh 45123 937- 981-4007 darlakib@bright.net
KA8ZNY,N8OOY	Tom & Cheryl Taft	386 Cherry Street	Groveport	Oh 43125 836-3519 ka8zny@copper.net

**\*Email\* I'm adding Email addresses. I will send each listed recipient Email notices of upcoming special events. If you'd like to be included in these mailings, let me know by letter, Tuesdaynite net or by return Email, and I'll put you on the list...WA8RMC towslee@ee.net.**

ATCO Newsletter  
c/o Art Towslee-WA8RMC  
180 Fairdale Ave  
Westerville, Ohio 43081

---

**FIRST CLASS MAIL**

---

---

**REMEMBER...CLUB DUES ARE NEEDED.  
CHECK MAILING LABEL FOR THE EXPIRATION DATE AND SEND KF8QU A CHECK IF EXPIRED.**

---